

FLUKE®

718 30G/100G

Pressure Calibrator

Users Manual

July 1998 Rev.3, 12/02

© 1998-2002 Fluke Corporation. All rights reserved. Printed in U.S.A.

All product names are trademarks of their respective companies.

Table of Contents

Title	Page
Introduction	1
Safety Information.....	2
Getting Acquainted with the Calibrator	6
Zeroing with Absolute Pressure Modules	8
Calibrating a P/I Transmitter	9
Using the Internal Pump	9
Using an External Pump	14
External Fluke Pressure Module Compatibility	16
Sourcing Loop Voltage	17
Maintenance	17
In Case of Difficulty	18
Cleaning.....	18
Calibration.....	18
Replacing the Batteries.....	19
Replacing the Fuse	20
Parts and Accessories	21
Specifications.....	24

718 30G/100G

Users Manual

Pressure Sensor Input, 718 30G	24
Pressure Sensor Input, 718 100G	24
Pressure Module Input, 718 30G and 718 100G	24
DC mA Input, 718 30G and 718 100G	24
Loop Supply 718 30G and 718 100G	24
General Specifications.....	25
How to Contact Fluke	26

List of Tables

Table	Title	Page
1.	Pressure Sensor Range and Resolution	2
2.	Safety Information	3
3.	International Electrical Symbols	5
4.	Pushbutton Functions.....	7
5.	Pump Features.....	9
6.	Recommended Pressure Modules	13
7.	Fluke Pressure Module Compatibility	16
8.	Replacement Parts	21

List of Figures

Figure	Title	Page
1.	Connection Technique	5
2.	Front Panel Features.....	6
3.	Pump Features.....	8
4.	Internal Pressure Sensor with Internal Pump	11
5.	Pressure Module with Internal Pump.....	12
6.	Pressure Module with External Pump	15
7.	Sourcing Loop Voltage	17
8.	Battery Replacement.....	19
9.	Fuse Replacement	20
10.	Replacement Parts.....	23

Pressure Calibrator

Introduction

The Fluke Model 718 30G and 718 100G Pressure Calibrators (hereafter called “Calibrator”) can do the following:

- Calibrate P/I (pressure to current) transmitters.
- Measure pressure via a 1/8-inch NPT pressure fitting and an internal pressure sensor or via a Fluke 700 Series Pressure Module.
- Measure current up to 24 mA.
- Simultaneously display pressure and current measurements.
- Supply loop voltage.

The Calibrator makes 5-digit pressure readings in the following units: psi, inH₂O at 4 °C, inH₂O at 20 °C, kPa, cmH₂O at 4 °C, cmH₂O at 20 °C, bar, mbar, kg/cm², inHg, and mmHg. Full scale pressure sensor input is as follows:

- Model 718 30G: 30 psi (206.85 kPa, 2.0685 bar).
“OL” appears at 33 psi.

- Model 718 100G: 100 psi (689.5 kPa, 6.895 bar).
“OL” appears at 120 psi.

The Calibrator measures pressure sensor inputs in the units shown in Table 1.

For Pressure Modules, full scale readings for all pressure ranges can be made in psi, kPa, and inHg units. To avoid display overflow, full scale readings are limited to 1000 psi in cmH₂O, mbar, and mmHg units, and 3000 psi in inH₂O units. Pressures of at least 15 psi must be measured for meaningful readings in bar and kg/cm² units.

Your Calibrator is supplied with a holster, two installed 9 V alkaline batteries, one set of TL75 test leads, one set of AC70A alligator clips, one 700-ILF In-Line Filter (to protect the pump), a Product Overview Manual, and a CD-Rom.

If the Calibrator is damaged or something is missing, contact the place of purchase immediately. Contact your Fluke distributor for information about accessories. See “How to Contact Fluke.” To order replacement parts or spares, see “Parts and Accessories.”

Table 1. Pressure Sensor Range and Resolution

Displayed Pressure Units	Model 718 30G Range and Resolution	Model 718 100G Range and Resolution
psi	-12.000 to 30.000 psi	-12.00 to 100.00 psi
inH ₂ O at 4°C	-332.16 to 830.40 inH ₂ O	-332.2 to 2768.0 inH ₂ O
inH ₂ O at 20°C	-332.75 to 831.87 inH ₂ O	-332.8 to 2772.9 inH ₂ O
cmH ₂ O at 4°C	-843.6 to 2109.0 cmH ₂ O	-843.6 to 7030.0 cmH ₂ O
cmH ₂ O at 20°C	-845.2 to 2113.0 cmH ₂ O	-845.2 to 7043.0 cmH ₂ O
bar	-0.8274 to 2.0685 bar	-0.8274 to 6.8950 bar
mbar	-827.4 to 2068.5 mbar	-827.4 to 6895.0 mbar
kPa	-82.74 to 206.85 kPa	-82.74 to 689.50 kPa
inHg	-24.432 to 61.080 inHg	-24.43 to 203.60 inHg
mmHg	-620.6 to 1551.4 mmHg	-620.6 to 5171.5 mmHg
kg/cm ²	-0.8437 to 2.1090 kg/cm ²	-0.8437 to 7.0306 kg/cm ²

Safety Information

Use the Calibrator only as specified in this instruction sheet, otherwise the protection provided by the Calibrator may be impaired.

A **Warning** identifies conditions and actions that pose hazard(s) to the user; a **Caution** identifies conditions and actions that may damage the Calibrator or the equipment under test.

Table 2. Safety Information

⚠ Warning

To avoid possible electric shock or personal injury:

- Never apply more than 30 V between the mA terminals, or between either of the mA terminals and earth ground.
- Remove the test leads from the Calibrator before you open the battery door.
- Make sure the battery door is closed and latched before you operate the Calibrator.
- Do not operate the Calibrator if it is damaged.
- Do not operate the Calibrator around explosive gas, vapor, or dust.
- When using probes, keep fingers behind the finger guards on the probes.
- Use only two 9 V batteries, properly installed in the calibrator case, to power the calibrator.
- Follow all equipment safety procedures.
- Turn off circuit power before connecting the calibrator mA and COM terminals in the circuit. Place calibrator in series with the circuit.
- When servicing the Calibrator, use only specified replacement parts.
- Do not allow water inside the case.

Table 2. Safety Information (cont.)

⚠ Warning

To avoid false readings, which could lead to possible electric shock or personal injury, replace the battery as soon as the battery indicator **+** appears.

To avoid a violent release of pressure in a pressurized system, shut off the valve and slowly bleed off the pressure before you attach or detach the internal pressure sensor or Pressure Module fitting to the pressure line.

To avoid overpressure damage, do not apply pressure to the internal pressure sensor input that exceeds the following:

- Model 718 30G: 30.000 psi, 206.85 kPa, or 2.0685 bar. “OL” appears at 33 psi.
- Model 718 100G: 100.00 psi, 689.5 kPa, or 6.895 bar. “OL” appears at 120 psi.

To avoid mechanically damaging the Calibrator:

- Do not apply torque between the pressure fitting and the Calibrator case. See Figure 1 for the proper use of tools.

To avoid misleading readings, disconnect the Pressure Module connector at the Calibrator.

To avoid damage to the Pressure Module, refer to the related *Instruction Sheet*.

To avoid damage to the pump, use with dry air and non-corrosive gases only. Use of the included Fluke 700-ILF In-Line Filter will help isolate the pump from contaminants. Failure to use the included filter may void the pump warranty if contamination occurs.

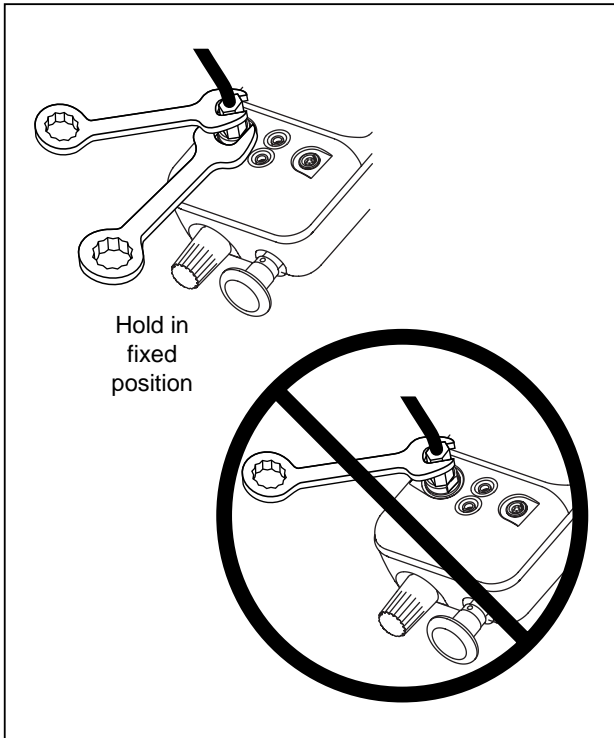

wh001f.eps

Figure 1. Connection Technique

Table 3. International Electrical Symbols

Symbol	Meaning
	Earth ground
	Fuse
	Battery
	Refer to this instruction sheet for information about this feature.
	Double insulated
	Conforms to relevant Canadian Standards Association directives.
	Conforms to relevant European Union directives
	Pressure

Getting Acquainted with the Calibrator

Press **Ⓞ** to turn the Calibrator on and off. The Calibrator displays pressure and current measurements simultaneously. See Figure 2.

The upper part of the display shows the applied pressure or vacuum. (Vacuum is shown as a negative value.) Press **UNITS** to select a different unit. When you cycle the power off and on, the Calibrator retains the unit you last used.

The lower part of the display shows the current (up to 24 mA) applied to the current (mA) inputs. The current inputs are fused with a 0.125 A, 250 V fast fuse (Littelfuse® type 2AG).

To source loop voltage, press **UNITS** while pressing **Ⓞ** on.

Pushbutton operation is described in Table 4. Pump features are shown in Figure 3 and described in Table 5.

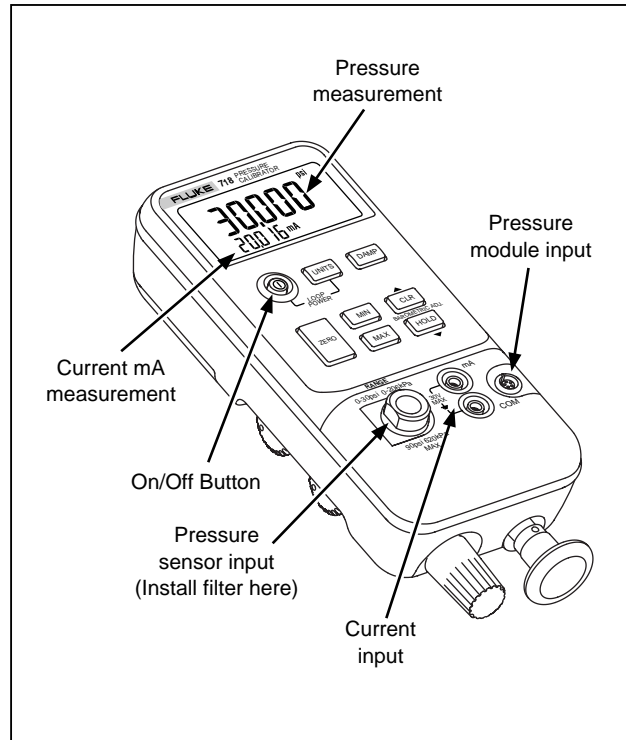







Figure 2. Front Panel Features

wh005f.eps

Table 4. Pushbutton Functions

Pushbutton	Description
UNITS	Press to select a different pressure unit. All units are available when the pressure sensor input is used. For higher pressure module inputs, inappropriate (out-of-range) units are not available. Press  on while pressing  to source loop voltage.
DAMP	Turns pressure reading damping on and off. With damping on, the Calibrator averages several measurements before displaying a reading.
ZERO	Press to zero the pressure display. Vent pressure to atmosphere before you press this pushbutton. With an Absolute Pressure Module, see special instructions below.
MIN	Press and hold to read the minimum pressure and current readings since power was turned on or  was pressed.
CLR	Press to clear the MIN and MAX memories.
MAX	Press and hold to read the maximum pressure and current readings since power was turned on or  was pressed.
HOLD	Press  to freeze the display. The HOLD symbol appears on the display. Press  again to resume normal operation.

Zeroing with Absolute Pressure Modules

For zeroing, adjust the Calibrator to read a known pressure. This can be barometric pressure, if it is accurately known, for all but the 700PA3 module. An accurate pressure standard can also apply a pressure within range for any Absolute Pressure Module. Adjust the Calibrator reading as follows:

1. Press and hold **ZERO**.
2. Press **CLR** to increase or **HOLD** to decrease the Calibrator reading to equal the applied pressure.
3. Release **ZERO** to exit the zeroing procedure.

Press the **UNITS** button to convert to any convenient measurement display unit.

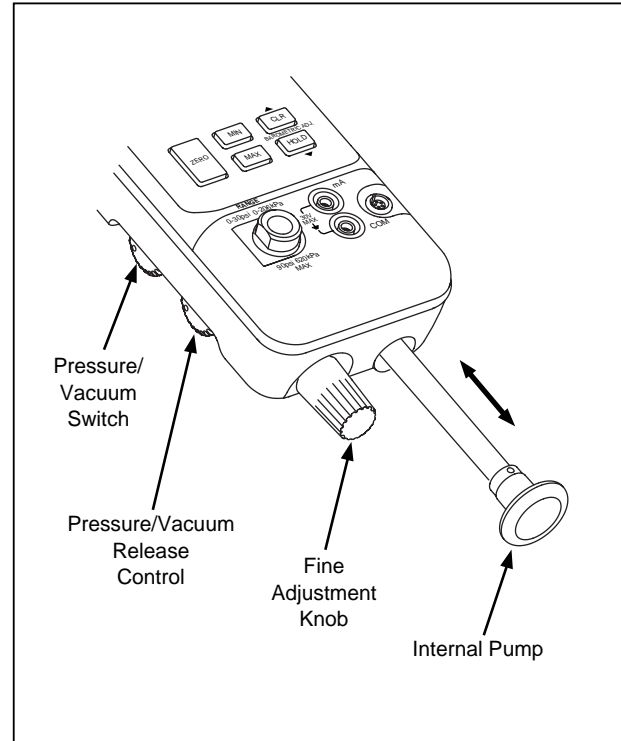

Figure 3. Pump Features

wh009f.eps

Table 5. Pump Features

Item	Description
Pressure Vacuum Switch	Rotate forward (clockwise) for pressure, backward (counter-clockwise) for vacuum.
Pressure Vacuum Release Valve	Rotate fully backward (counter-clockwise) to release all pressure or vacuum. (Rotate slightly for partial release.) Rotate fully forward (clockwise) to close valve.
Fine Adjustment Knob	Rotate either direction for precise adjustment of applied pressure or vacuum. Full rotation is about 30 turns.
Internal Pump	Increase pressure on the inward stroke. In vacuum mode, decrease pressure on the outward stroke.

Calibrating a P/I Transmitter

To calibrate a P/I (pressure to current) transmitter, apply a pressure to the transmitter and measure the transmitter's current loop output. You can apply pressure with the Calibrator's internal pump or with an external pump. An internal relief valve activates when pressure/vacuum exceeds the rating for the Calibrator model (50-60 psi for 718 30G, 140-150 psi for 718 100G.)

Warning

To avoid a violent release of pressure or vacuum, always depressurize the system slowly using the pressure/vacuum release control before detaching any pressure line.

Using the Internal Pump

The internal pump can provide 30 psi (2.0685 bar) for Model 718 30G or 100 psi (6.895 bar) for Model 718 100G.

The preferred use for the internal pump is shown in Figure 4, where the calibrator displays pressure measured with the internal sensor and provided by the internal pump.

The internal pump can also be used with certain Fluke 700 Series Pressure Modules. In this case, pressure measured by the Pressure Module is displayed by the Calibrator. Appropriate Pressure Modules for each

calibrator model are identified in Table . Figure 5 shows the internal pump being used with a pressure module.

⚠ Warning

If both a pressure module and the internal sensor are connected, the Calibrator displays ONLY the pressure module measurement.

To use the Calibrator's internal pump, refer to Figure 3 and perform the following steps:

1. Depressurize the line before connecting the Calibrator.
2. Connect the pressure transmitter to the calibrator internal sensor as shown in Figure 4 (for internal pressure sensor measurements) or Figure 5 (for pressure module measurements.)

Note

To avoid leaks, use Teflon tape or similar sealant on all pressure connections.

3. Make sure the pressure/vacuum switch is in the desired position. Forward (clockwise) is for pressure; backward (counter-clockwise) is for vacuum.

4. Turn the pressure/vacuum release control backward (counter-clockwise) to vent pressure/vacuum from the pump.
5. Press **ZERO** to zero the pressure display.
6. Turn the fine adjustment knob to mid-range.
7. Turn the pressure/vacuum release control forward (clockwise) to close the release valve.
8. Work the pump handle in and out to apply incrementally larger pressure/vacuum changes. Shorten the stroke to apply smaller increments of pressure/vacuum change.
9. To make very small pressure/vacuum changes, use the fine adjustment knob.

Note

This knob adjusts a small internal reservoir to vary the total volume. With larger external pressure/vacuum volumes, this control will adjust pressure or vacuum within a smaller range.

10. Depressurize the system before disconnecting the pressure line.

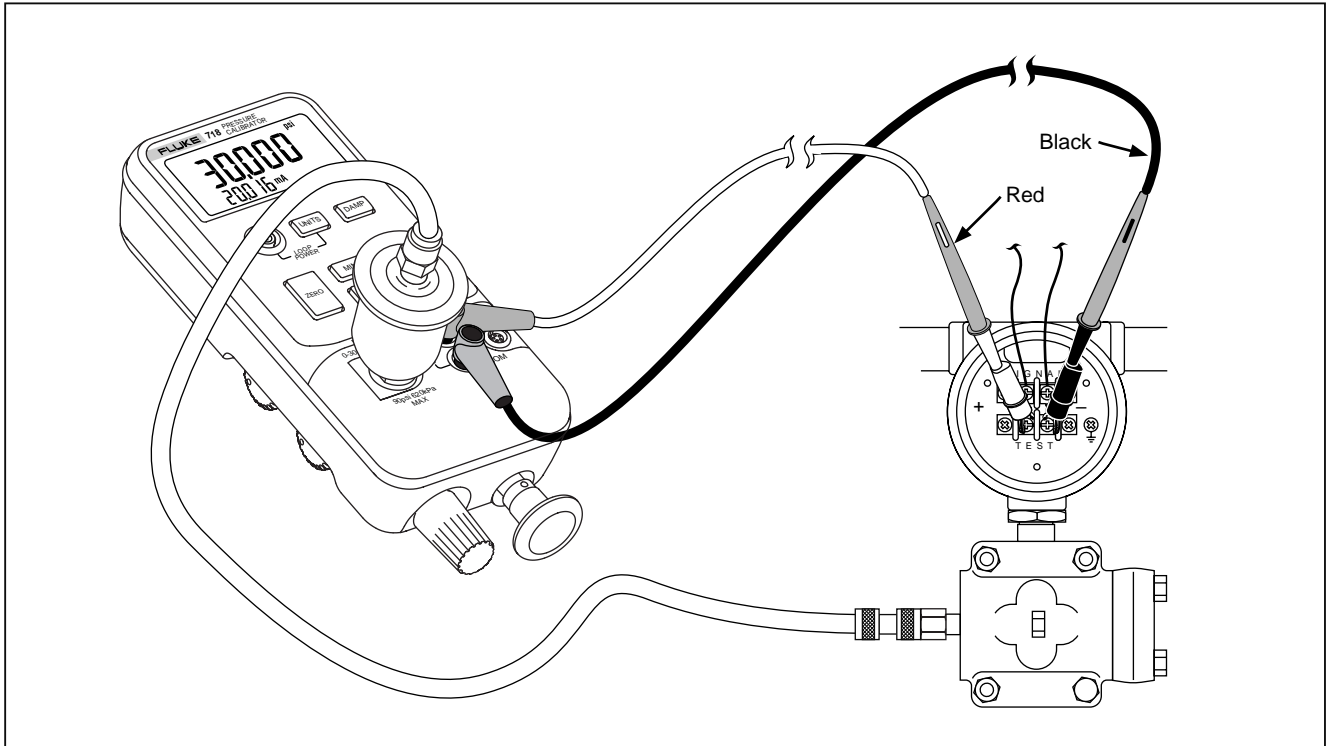

Figure 4. Internal Pressure Sensor with Internal Pump

wh002f.eps

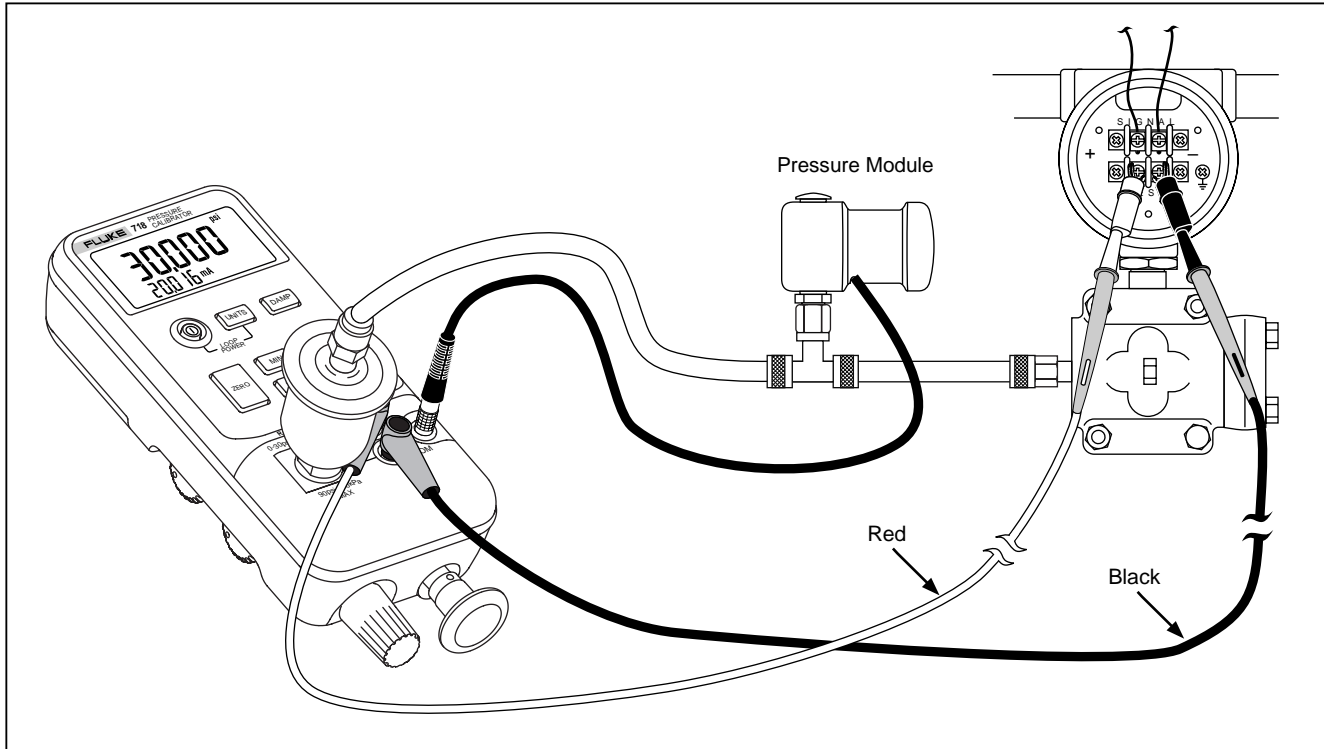

Figure 5. Pressure Module with Internal Pump

wh010f.eps

Table 6. Recommended Pressure Modules

Pressure Module	External Pump	Internal Pump	
	718 30G/100G	718 30G	718 100G
700P00	X	X	X
700P01	X	X	X
700P02	X	X	X
700P22	X	X	X
700P03	X	X	X
700P23	X	X	X
700P04	X	X	X
700P24	X	X	X
700P05	X	X	X
700P06	X		X
700P27	X		
700P07	X		
700P08	X		
700P09	X		

Pressure Module	External Pump	Internal Pump	
	718 30G/100G	718 30G	718 100G
700PA3	X	X	X
700PA4	X	X	X
700PA5	X	X	X
700PA6	X		X
700PV3	X	X	X
700PV4	X	X	X
700PD2	X	X	X
700PD3	X	X	X
700PD4	X	X	X
700PD5	X	X	X
700PD6	X		X
700PD7	X		
700P29	X		
700P30	X		
700P31	X		

Using an External Pump

⚠ Warning

To avoid damage to the Calibrator and possible release of pressure, do not connect the internal sensor to an external pressure source that exceeds 30 psi for Model 718 30G or 100 psi for Model 718 100G.

To develop higher pressure or vacuum, use an external pump (such as the Fluke Model 700PTP). Use a Fluke Pressure Module connected to the pressure module input on the Calibrator. Pressure modules are listed in Table . Make overall connections as shown in Figure 6.

Refer to setup and operating instructions included with the pressure module and pump.

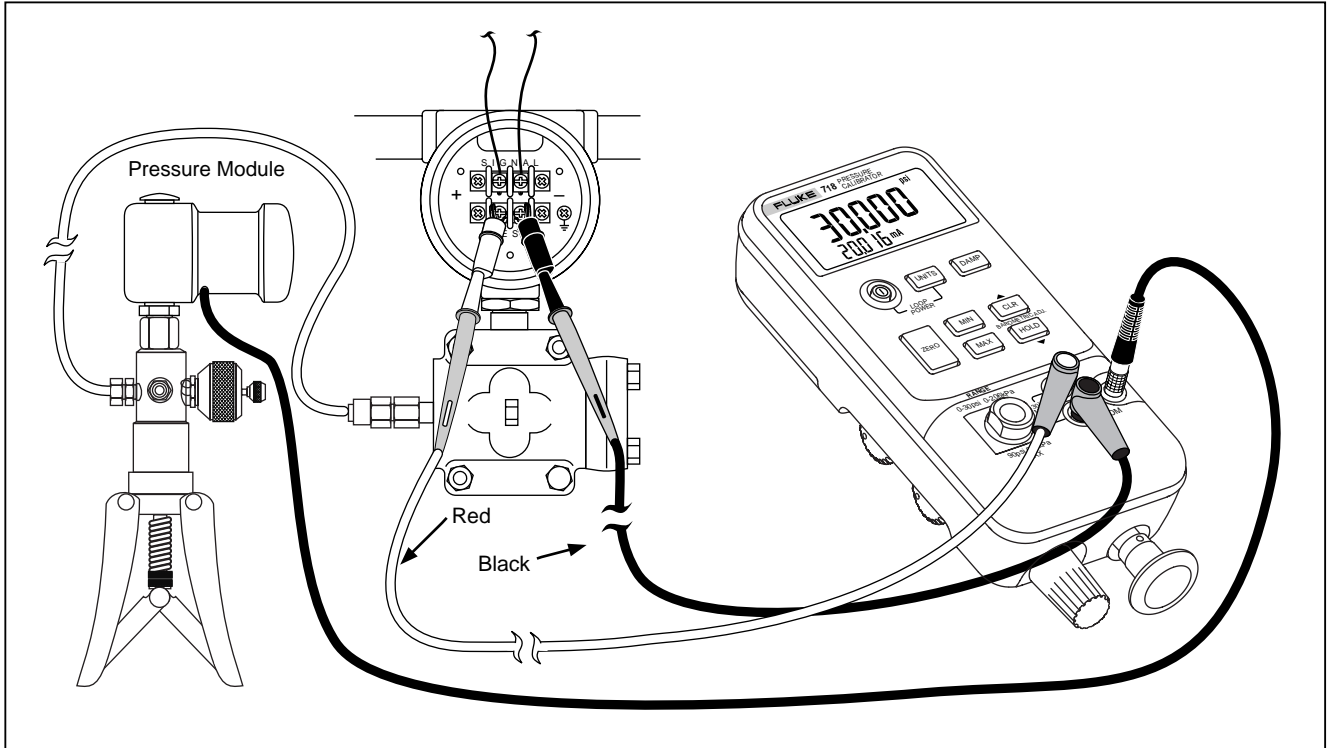

Figure 6. Pressure Module with External Pump

wh006f.eps

External Fluke Pressure Module Compatibility

If inappropriate units are selected, the output of Fluke 700P pressure modules can cause the calibrator display to overflow (OL), or displays values that are too low to be read. Refer to Table 7 for appropriate unit and range compatibility.

Table 7. Fluke Pressure Module Compatibility

Pressure Unit	Module Compatibility
psi	Available on all pressure ranges
inH ₂ O	All ranges through 3000 psi
cmH ₂ O	All ranges through 1000 psi
bar	15 psi and above
mbar	All ranges through 1000 psi
kPa	Available on all pressure ranges
inHg	Available on all pressure ranges
mmHg	All ranges through 1000 psi
kg/cm ²	15 psi and above

Sourcing Loop Voltage

The Calibrator can supply loop power at 24 V dc to a current transmitter that is disconnected from the system. Use the following procedure:

1. With power off, hold down **UNITS** while pressing **Ⓢ** on. “Loop” appears in the display.
2. With the transmitter disconnected from normal loop power, connect the Calibrator mA (+) and COM (-) test leads in series with the instrument current loop as shown in Figure 7. “Loop” disappears from the display once the transmitter starts drawing current.
3. Measure loop current in the mA display.
4. Press **Ⓢ** off to deactivate the 24 V dc supply when you are done sourcing loop voltage.

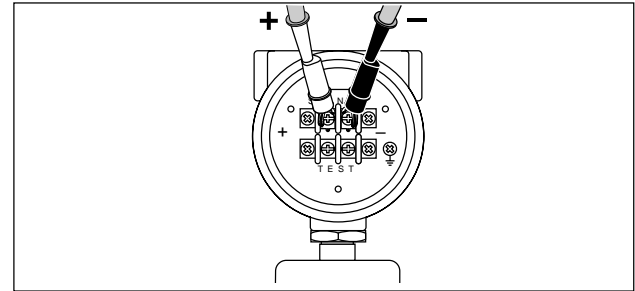

qo007f.eps

Figure 7. Sourcing Loop Voltage

Maintenance

⚠ Warning

To avoid possible electric shock, personal injury, or sudden release of pressure, review “Safety Information” earlier in this manual before proceeding.

For maintenance procedures not described in this instruction sheet, or if the Calibrator needs repair, contact a Fluke Service Center.

In Case of Difficulty

- Check the battery, test leads, pressure module, and pressure tubing. Follow replacement and connection instructions properly.
- Review this instruction sheet to make sure you are using the Calibrator correctly.

If the Calibrator needs repair, and the Calibrator is under warranty, see the warranty statement for terms. If the warranty has lapsed, the Calibrator can be repaired and returned for a fixed fee.

Cleaning

Periodically wipe the case with a damp cloth and detergent; do not use abrasives or solvents.

Calibration

Fluke recommends that you calibrate your Calibrator once a year to ensure that it performs according to its specifications. A calibration manual is available (PN 686540). Call 1-800-526-4731 from the U.S.A. and Canada. In other countries, contact a Fluke Service Center.

Replacing the Batteries

When the  symbol appears on the display, replace the two 9 V alkaline batteries. Refer to Figure 8.

Warning

To avoid false readings, which could lead to possible electric shock or personal injury, replace the batteries as soon as the battery indicator  appears.

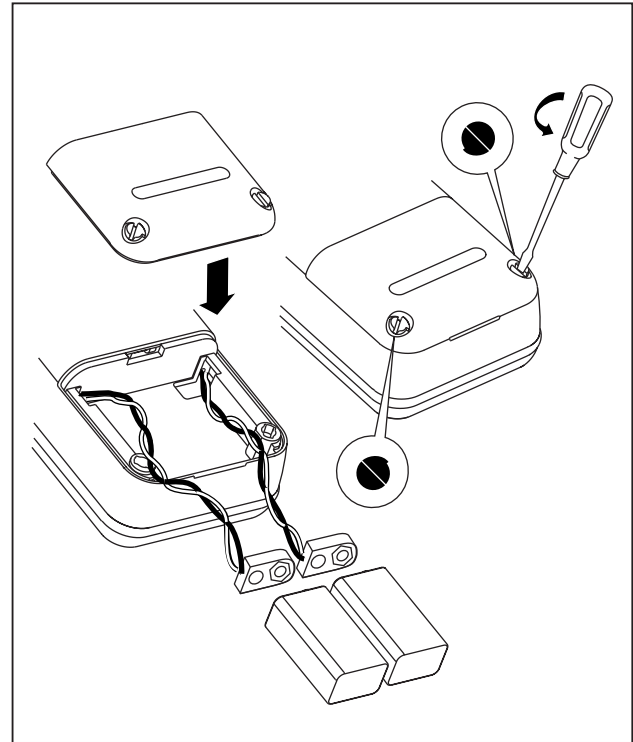

wh008f.eps

Figure 8. Battery Replacement

Replacing the Fuse

⚠ Warning

To avoid personal injury or damage to the Calibrator, use only a 0.125A 250 V fast fuse, Littelfuse® 2AG.

Fuse F1 is probably blown if the mA display reading does not respond to current applied to the current (mA) inputs. Refer to Figure 9. Replace the fuse as follows:

1. Remove the test leads and turn the Calibrator off.
2. Remove the battery door.
3. Remove the three Phillips-head screws from the case bottom and turn the case over.
4. Gently lift the top cover from the end nearest the mA inputs until it unsnaps from the bottom cover.
5. Replace the fuse with a 0.125 A 250 V fast fuse, Littelfuse® type 2AG.
6. Carefully fit the case top and circuit board assembly together, making sure that the O-ring is properly seated between the pressure sensor and the pressure fitting on the case top. Fit the case bottom onto the case top, engaging the two snaps near the display end of the case. Reinstall the three screws.
7. Replace the battery door.

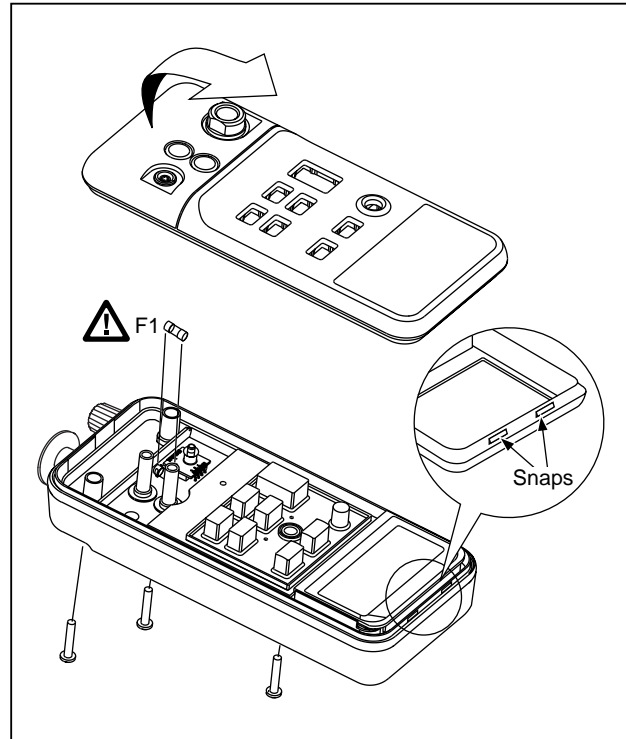

wh003f.eps

Figure 9. Fuse Replacement

Parts and Accessories

Refer to Table 8 and Figure 10.

Table 8. Replacement Parts

Item	Description	Part/ Mod. No.	Qty
AC70A	Alligator clips	AC70A	1
BT1, BT2	9 V battery, ANSI/NEDA 1604A or IEC 6LR61	614487	2
Holster	Holster, Yellow	664182	1
△F1	Fuse, 125 mA, 250 V fast △To ensure safety, use exact replacement only.	686527	1
H2, 3, 4	Case screw	832246	3
H5, 6	Battery door fasteners	948609	2
H7, 8	Bracket screw	641131	2
MP1	LCD bezel, 718 30G	664158	1
MP1	LCD bezel, 718 100G	664169	
MP2	LCD	686482	1
MP3, 4	Pump retainer bracket	664201	2
MP5	Gasket	664208	1
MP6	Pump assembly, 718 30G	691383	1
MP6	Pump assembly, 718 100G	691748	1
MP7, 8	Selector knob	664193	2
MP9	Vernier adjust knob	664190	1
MP10	Pump handle knob	664185	1
MP11, 12, 13	O-ring	146688	3
MP14	Spacer	687449	1

718 30G/100G*Users Manual*

Item	Description	Part/ Mod. No.	Qty
MP85	Case top/connector, 718 30G	690997	1
MP85	Case top/connector, 718 100G	691147	1
MP86	Case bottom	664174	1
MP89, 90	Non-skid foot	885884	2
MP92	Battery door	664177	1
S1	Keypad	687068	1
TL20	Industrial test lead set	TL20	Opt
TL75	Test lead set	TL75	1
TM1	718 Product Overview Manual	1549632	1
-	718 CD-ROM (contains Users Manual)	1574463	1
-	71X Series Calibration Manual	686540	Opt
-	Pump seal kit	691805	Opt
700-ILF	In-Line Filter	700-ILF	1

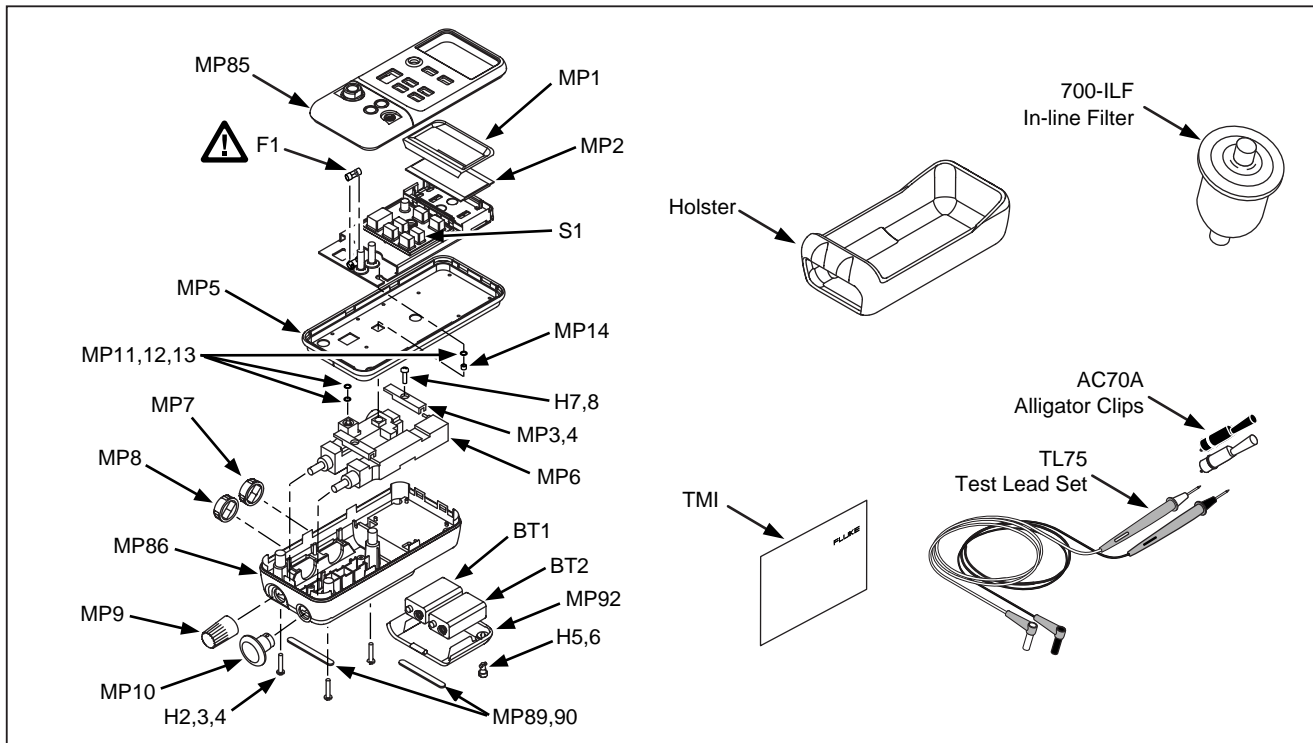

wh004f.eps

Figure 10. Replacement Parts

Specifications

Specifications are based on a one year calibration cycle and apply for ambient temperature from +18 °C to +28 °C unless stated otherwise. “Counts” are the number of increments or decrements of the least significant digit.

Pressure Sensor Input, 718 30G

Range	Accuracy
-12 to 30 psi (-82.7 to 206.85 kPa)	±0.05 % of range
<i>Maximum nondestructive pressure: 3X top of range (90 psi, 620 kPa, 6.2 bar)</i> <i>Temperature coefficient: 0.01 % of range per °C for temperature ranges -10 °C to 18 °C and 28 °C to 55 °C</i>	

Pressure Sensor Input, 718 100G

Range	Accuracy
-12 to 100 psi (-82.7 to 689.5 kPa)	±0.05 % of range
<i>Maximum nondestructive pressure: 2X top of range (200 psi, 1380 kPa, 13.8 bar)</i> <i>Temperature coefficient: 0.01 % of range per °C for temperature ranges -10 °C to 18 °C and 28 °C to 55 °C</i>	

Pressure Module Input, 718 30G and 718 100G

Range	Resolution	Accuracy
(determined by Pressure Module)		

DC mA Input, 718 30G and 718 100G

Range	Resolution	Accuracy, ±(% of Reading + Counts)
24 mA	0.001 mA	0.025 + 1
<i>Overload protection: 125 mA, 250 V fast acting fuse</i> <i>Temperature coefficient: 0.005 % of range per °C for temperature ranges -10 °C to 18 °C and 28 °C to 55 °C</i>		

Loop Supply 718 30G and 718 100G

24 V dc nominal

General Specifications

Maximum voltage applied between either mA terminal and earth ground or between the mA terminals: 30 V

Storage temperature: -40 °C to 60 °C

Operating temperature: -10 °C to 55 °C

Operating altitude: 3000 meters maximum

Relative humidity: 95 % up to 30 °C, 75 % up to 40 °C, 45 % up to 50 °C, and 35 % up to 55 °C

Vibration: Random 2 g, 5 Hz to 500 Hz

Shock: 1 meter drop test

Safety: Certified as compliant to CAN/CSA C22.2 No. 1010.2:1995. Complies with ANSI/ISA S82.01-1995.

Power requirements: Two 9 V batteries (ANSI/NEDA 1604A or IEC 6LR61)

Size: 60 mm H x 87 mm W x 210 mm L (2.38 in H x 3.41 in W x 8.28 in L); with holster: 66 mm H x 94 mm W x 216 mm L (2.61 in H x 3.72 in W x 8.5 in L)

Weight: 737 g (26 oz); with holster: 992 g (35 oz)

LIMITED WARRANTY & LIMITATION OF LIABILITY

This Fluke product will be free from defects in material and workmanship for three years (one year for pump assembly) from the date of purchase. This warranty does not cover fuses, disposable batteries or damage from accident, neglect, misuse or abnormal conditions of operation or handling. Resellers are not authorized to extend any other warranty on Fluke's behalf. To obtain service during the warranty period, send your defective Calibrator to the nearest Fluke Authorized Service Center with a description of the problem.

THIS WARRANTY IS YOUR ONLY REMEDY. NO OTHER WARRANTIES, SUCH AS FITNESS FOR A PARTICULAR PURPOSE, ARE EXPRESSED OR IMPLIED. FLUKE IS NOT LIABLE FOR ANY SPECIAL, INDIRECT, INCIDENTAL OR CONSEQUENTIAL DAMAGES OR LOSSES, ARISING FROM ANY CAUSE OR THEORY. Since some states or countries do not allow the exclusion or limitation of an implied warranty or of incidental or consequential damages, this limitation of liability may not apply to you.

How to Contact Fluke

To order accessories, receive operating assistance, or get the location of the nearest Fluke distributor or Service Center, call:

USA: 1-888-99-FLUKE (1-888-993-5853)

Canada: 1-800-36-FLUKE (1-800-363-5853)

Europe: +31 402-678-200

Japan: +81-3-3434-0181

Singapore: +65-738-5655

Anywhere in the world: +1-425-446-5500

Or, visit Fluke's Web site at www.fluke.com.

Address correspondence to:

Fluke Corporation

P.O. Box 9090,

Everett, WA 98206-9090

U.S.A.

Fluke Europe B.V.

P.O. Box 1186,

5602 BD Eindhoven

The Netherlands